

GATE CONTROLLERS

# GATOR WiFi Gate Controller

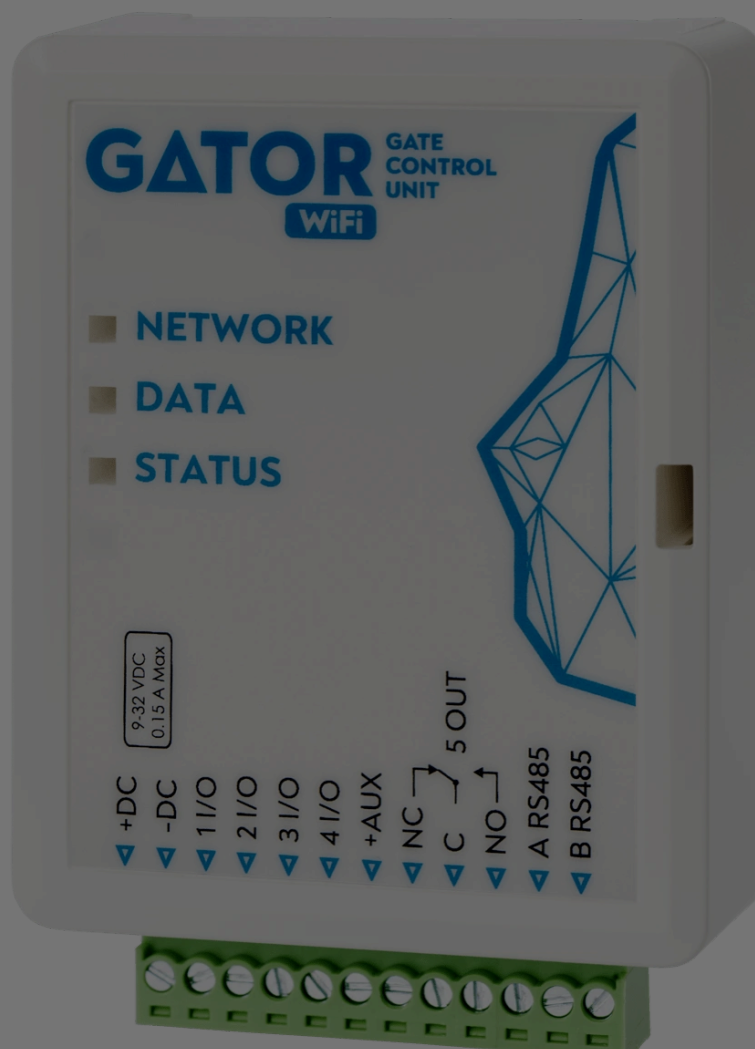

## I. Description

### Cookie consent

We use cookies to measure the effectiveness of our documentation and whether users find what they're searching for. With your consent, you're helping us to make our documentation better.

Google Analytics

Accept

Reject



## 1.1 Features

### Remote control

- With Mobile application *Protegeus2*.

### Messages for users

- Sends messages about events to the *Protegeus2* application.

### Messages for security company

- Sends event information in Contact ID codes to TRIKDIS software and hardware receivers, which work with any monitoring software.
- Can simultaneously send event messages to the receiver of the safety company and work with the *Protegeus2* app.
- If connection with the main receiver is lost, the messages are automatically sent to a backup receiver.

### Inputs and outputs

- 4 universal inputs/outputs. Mode of operation is set as either input (NO; NC; EOL) or output.
- 1 output (OUT) - relay.
- With the iO-LORA expander, one additional input and one output (relay contact) can be added. A total of 8 iO-LORA expanders can be added (adding up to 8 additional inputs and 8 additional outputs).

### Settings and installation

- Quick and easy installation.
- Addition of new users and deletion of existing users can be done with the *Protegeus2* app (when logged in with administrator rights), *TrikdisConfig* software.
- Device can be configured either by connecting a USB Mini-B cable or remotely with the

### Cookie consent

We use cookies to measure the effectiveness of our documentation and whether users find what they're searching for. With your consent, you're helping us to make our documentation better.

- Google Analytics



## 1.2 Specifications

Parameter	Description
Power supply voltage	9-32 V DC
Current consumption	150 mA
Universal inputs/outputs	4, can be set either as input IN with type: NC, NO, EOL=10 kΩ, or output OUT (open collector (OC) 50 mA)
Output	1 vnt., relay, 1 A 30 V DC, 0,5 A 125 V AC
Connection to CMS	TCP/IP or UDP/IP via Wi-Fi
Event transmission protocol	TRK_TCP or TRK_UDP
Encryption key	6 symbol encryption key
Wi-Fi frequency	2,4 GHz
Wi-Fi protocol	802.11 b/g/n
Security mode	WPA, WPA2, WPA mixed
Network configuration type	DHCP or manual network configuration (using phone or laptop)
Unsent events memory	Up to 60 events
Event log memory	Up to 5000 events
Users who have permission to control	1000
Supported modules	iO-LORA – expander module (when using iO-LORA, an RF-LORA transceiver must be connected to GATOR WiFi)
Operating environment	Temperature from -10 °C to +50 °C, relative air humidity – up to 80 % at +20 °C
Dimensions	88 x 62 x 26 mm
Weight	80 g

## 1.3 Controller elements

1. Light indicators.
2. Frontal case opening slot.
3. USB Mini-B port for controller programming.

### Cookie consent

We use cookies to measure the effectiveness of our documentation and whether users find what they're searching for. With your consent, you're helping us to make our documentation better.

- Google Analytics

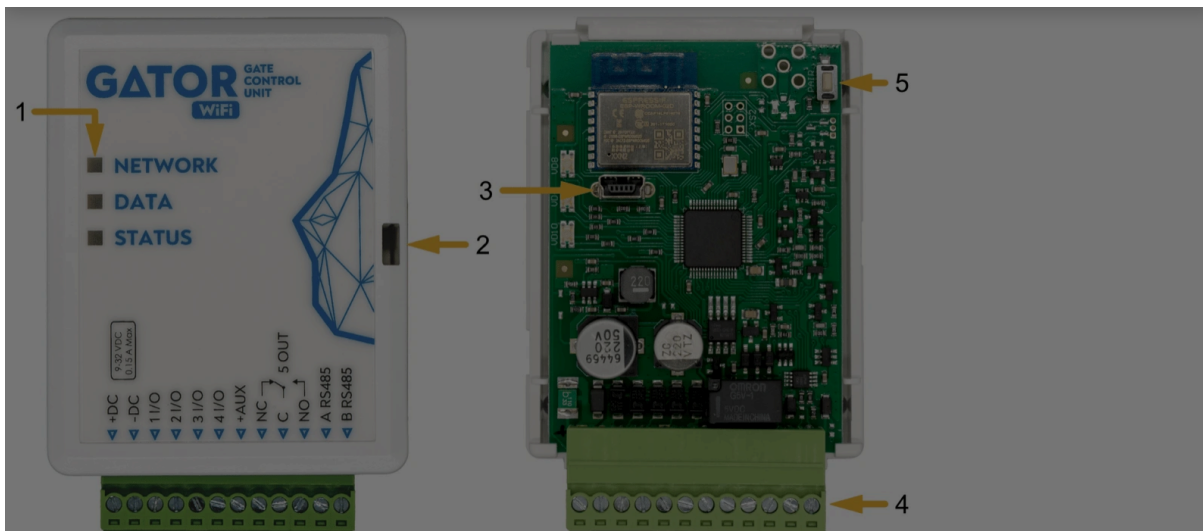

### 1.4 Purpose of terminals

Terminal	Description
+DC	Power terminal (9-32 V DC positive)
-DC	Power terminal (9-32 V DC negative)
1 I/O	Input/output (factory setting: input, NO)
2 I/O	Input/output (factory setting: input, NO)
3 I/O	Input/output (factory setting: type OC output)
4 I/O	Input/output (factory setting: type OC output)
+AUX	Positive power terminal for external devices
NC	Relay terminal NC
C	Relay terminal C
NO	Relay terminal NO
A RS485	RS485 bus A terminal
B RS485	RS485 bus B terminal

### Cookie consent

We use cookies to measure the effectiveness of our documentation and whether users find what they're searching for. With your consent, you're helping us to make our documentation better.

Google Analytics



## 1.5 LED indication of operation

Indicator	Light status	Description
NETWORK	Green solid	Connected to Wi-Fi network
NETWORK	Green blinking	Trying to connect to Wi-Fi network
NETWORK	Yellow blinking	Indication of signal strength from 0 to 5.
NETWORK	Flashing green yellow quickly	Wi-Fi configuration mode
DATA	Green solid	Message is being sent
DATA	Yellow solid	There are unsent event messages in the data buffer
STATUS	Green blinking	No operation problems
STATUS	1 red blink	Unable to connect to Wi-Fi network
STATUS	2 red blinks	Poor Wi-Fi signal strength
STATUS	3 red blinks	Unable to connect to the IP receiver using the primary channel
STATUS	4 red blinks	Unable to connect to Protegus2 server
STATUS	5 red blinks	Unable to connect to both receiver channels
STATUS	6 red blinks	Internal clock of the GATOR WiFi is not set
STATUS	7 red blinks	Low power supply voltage

If the LED indication is not working, check the power supply and connections.

### NOTE

Before beginning installation, make sure that you have the necessary components:

1. USB Mini-B type cable for configuration.
2. Cable consisting of at least 4 wires for connecting the controller.

## Cookie consent

We use cookies to measure the effectiveness of our documentation and whether users find what they're searching for. With your consent, you're helping us to make our documentation better.

Google Analytics



## 1.6 Controller *GATOR WiFi* standard packing list

- Controller <b>GATOR WiFi</b>	<b>1 pc.</b>
- Resistor 10 k $\Omega$	3 pcs.
- Double-sided adhesive tape (5 cm)	1 pc.
- Screw	2 pcs.

## 2. Wiring schematics for the controller *GATOR WiFi*

### 2.1 Fastening

1. Remove the top lid. Pull out the plug part of the terminal block.
2. Remove the PCB board.
3. Fasten the base of the case in the desired place using screws.
4. Reinsert the board and the terminal block.
5. Close the top lid.

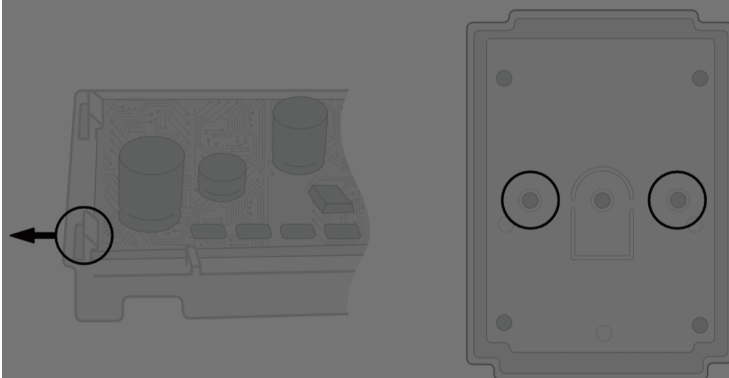

### 2.2 Schematic for connecting the power supply

Using wires, connect the GATOR WiFi controller according to the schematic shown below.

#### Cookie consent

We use cookies to measure the effectiveness of our documentation and whether users find what they're searching for. With your consent, you're helping us to make our documentation better.

Google Analytics

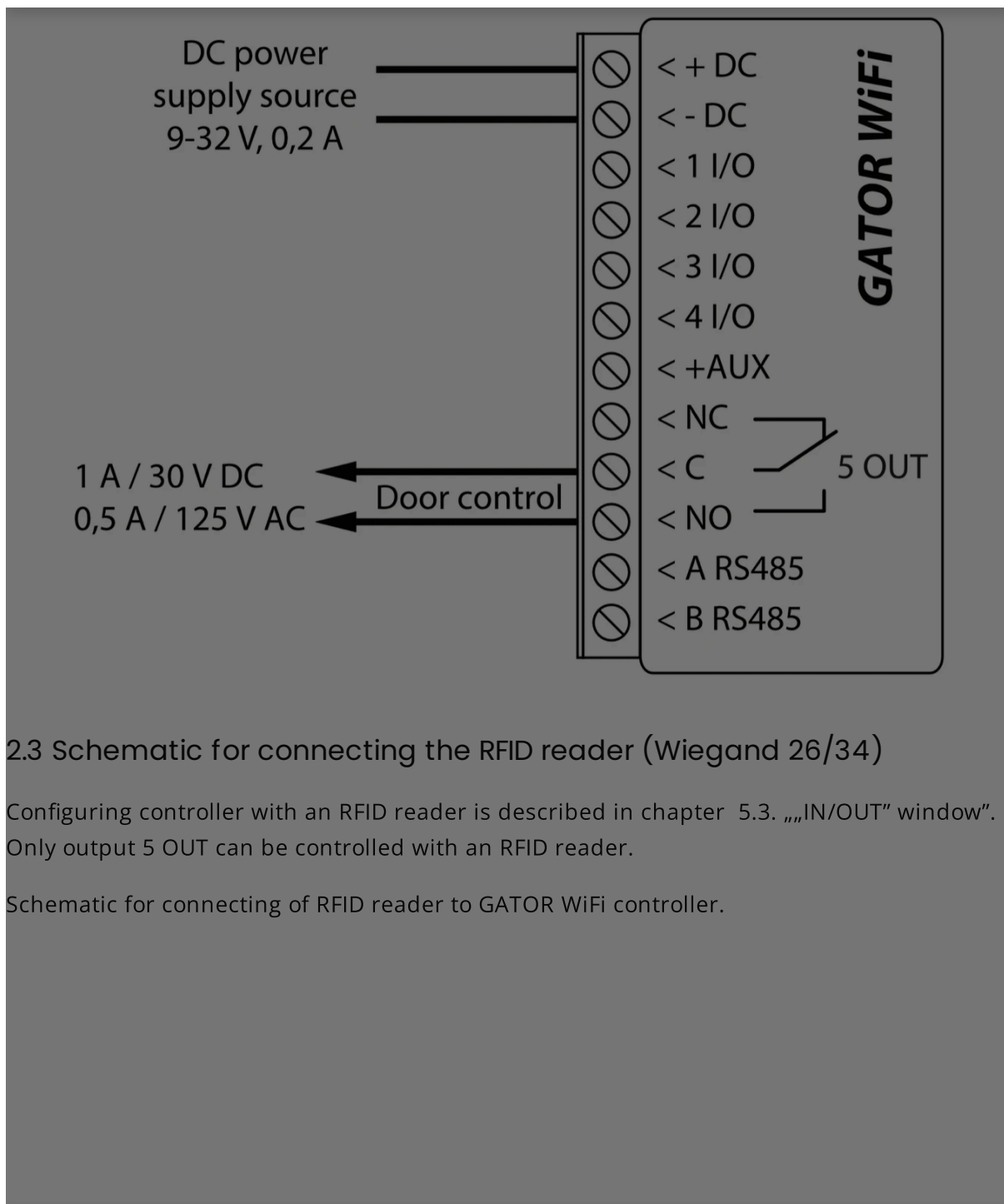

### 2.3 Schematic for connecting the RFID reader (Wiegand 26/34)

Configuring controller with an RFID reader is described in chapter 5.3. „IN/OUT” window”. Only output 5 OUT can be controlled with an RFID reader.

Schematic for connecting of RFID reader to GATOR WiFi controller.

#### Cookie consent

We use cookies to measure the effectiveness of our documentation and whether users find what they're searching for. With your consent, you're helping us to make our documentation better.

- Google Analytics

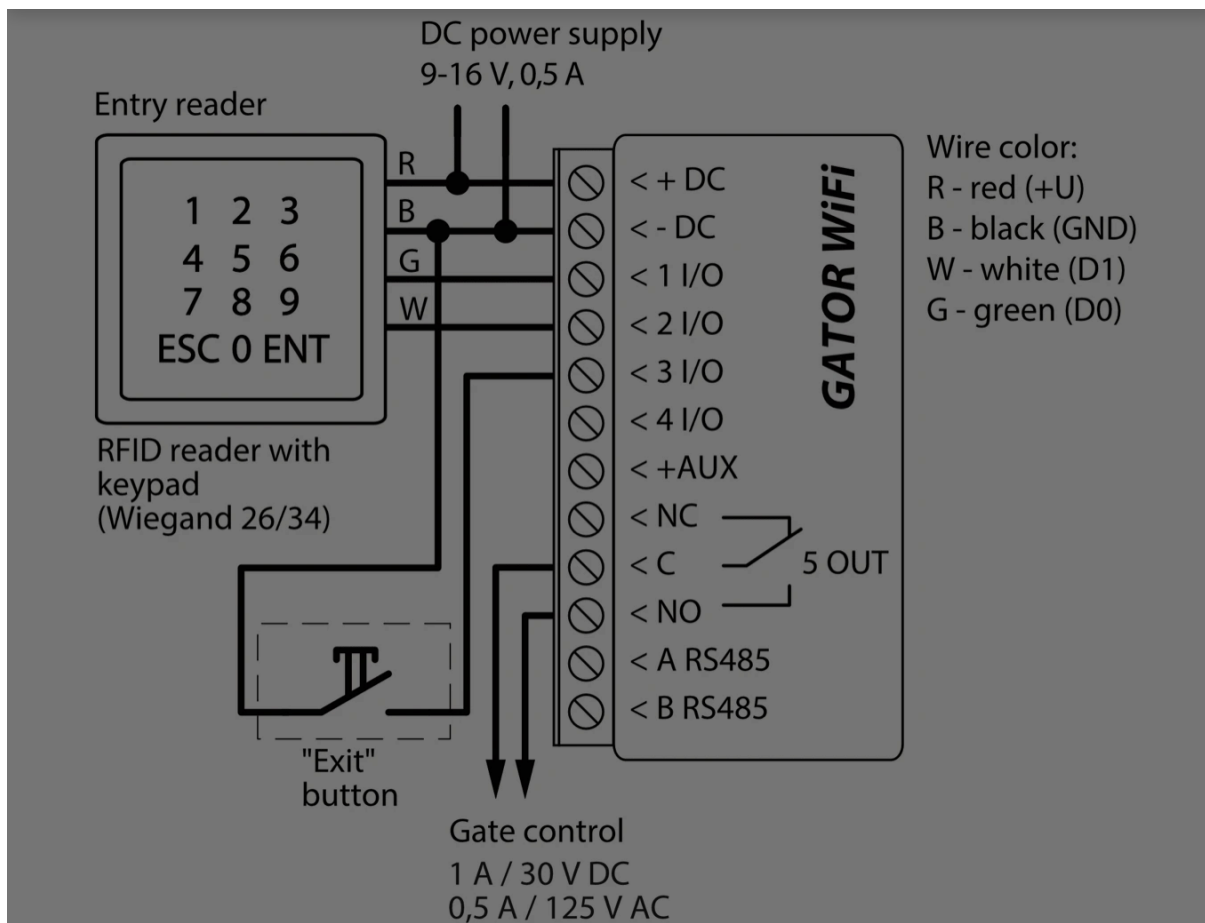

In the TrikdisConfig program, the **“Wiegand reader mode”** field must be selected. When by pressing the **“Exit”** button, the **“5OUT”** output of the controller will be activated for the set pulse duration.

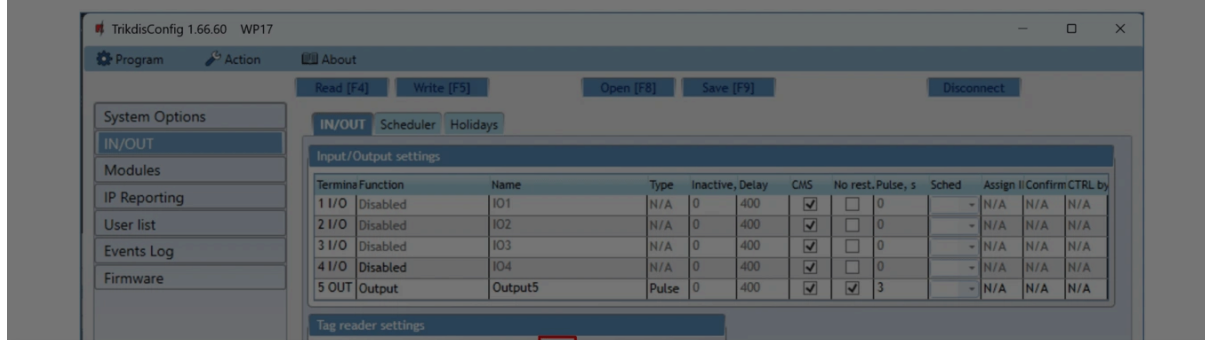

### Cookie consent

We use cookies to measure the effectiveness of our documentation and whether users find what they're searching for. With your consent, you're helping us to make our documentation better.

- Google Analytics

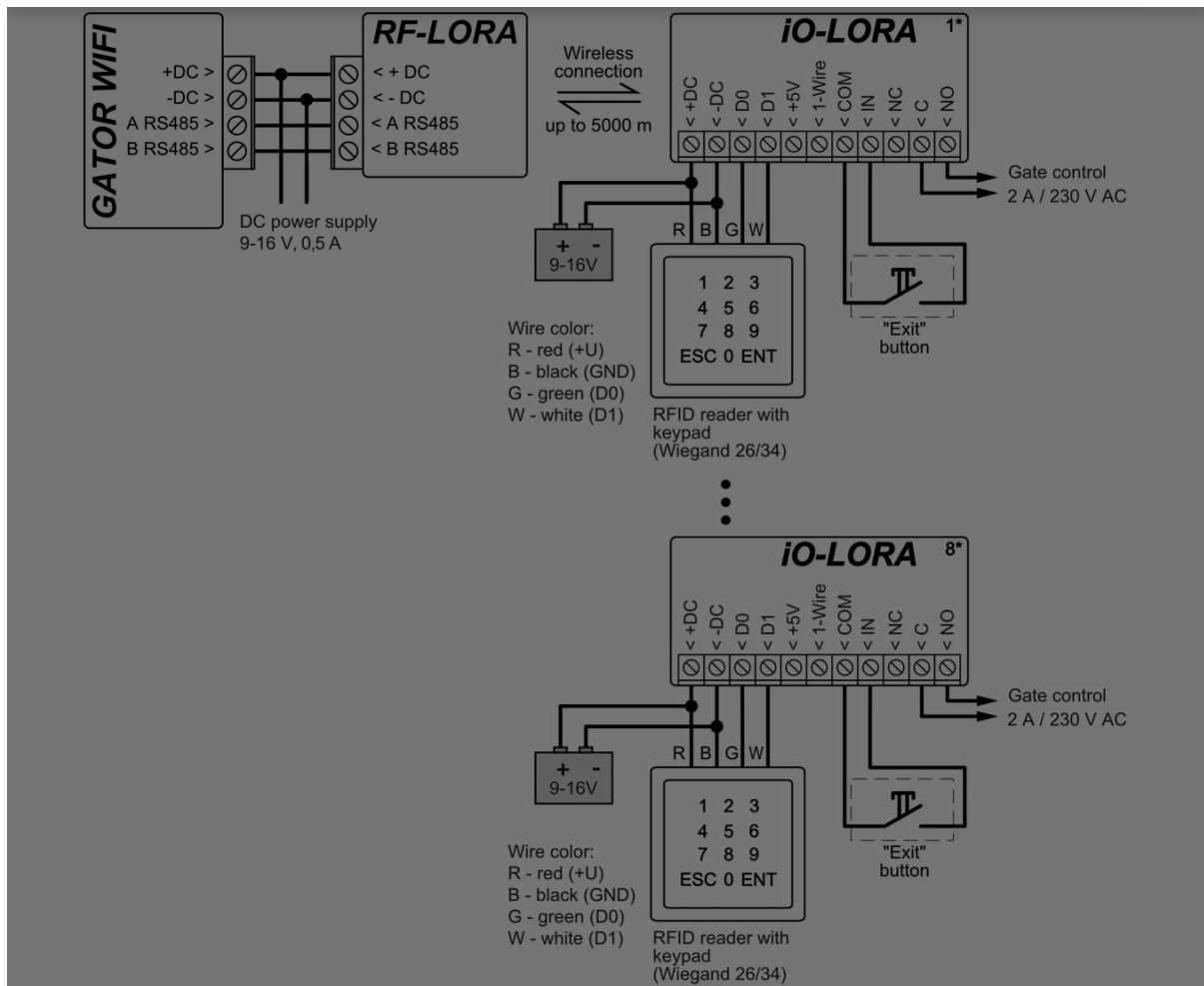

Launch TrikdisConfig. Connect GATOR WiFi via USB Mini-B cable to the computer or remotely. Press the **Read [F4]** button and the TrikdisConfig program will display the current controller settings. If requested, enter the Administrator or Installer 6-digit code in the pop-up window. Select **"iO-LORA controller"** from the **"Modules"** list. In the **"Serial No."** field, enter the serial number of the device.



### Cookie consent

We use cookies to measure the effectiveness of our documentation and whether users find what they're searching for. With your consent, you're helping us to make our documentation better.

- Google Analytics

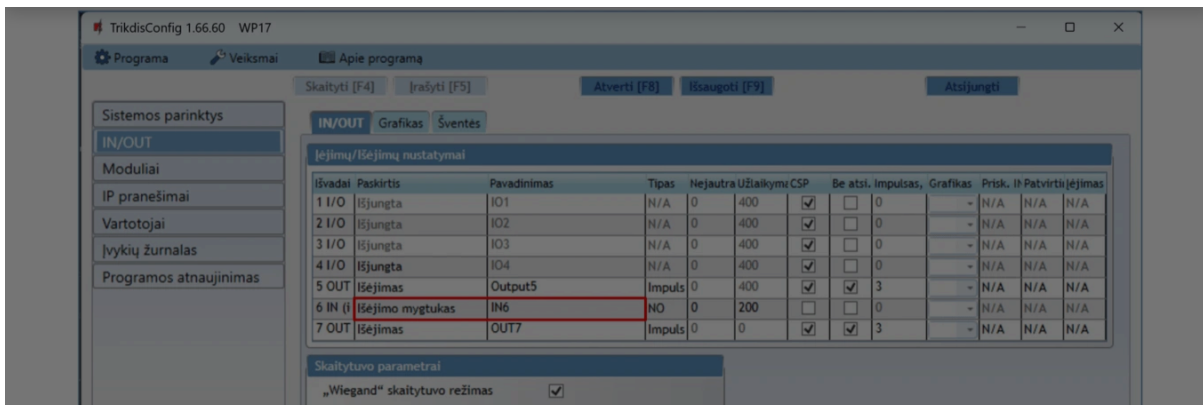

In the "Users" list, specify the number of the RFID card, the user's name, enable the permission to control the PGM output, specify the PGM output (which will be controlled by the user), the code. After completing the settings, click **Write [F5]**. Wait until the process of updating the controller settings is finished. Click "**Disconnect**" and disconnect the USB cable.

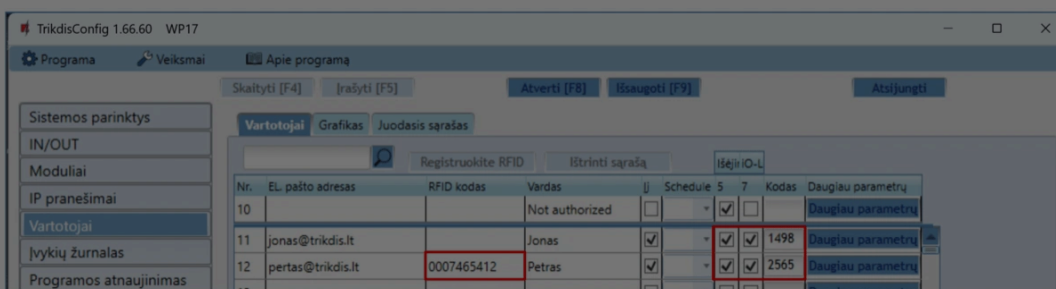

Activate PGM output with RFID card/code. Press the "**Exit**" button (the PGM output must activate for the set pulse duration).

## 2.5 Schematics for connecting inputs

The GATOR WiFi has four universal **I/O** (Inputs/Outputs) terminal, which can operate either as inputs or outputs. These inputs can operate in NC, NO, EOL modes. Connect the inputs according to the set input type (NC, NO, EOL) as is shown in the schematics bellow:

Normally open (NO)	Normally closed (NC)	Normally closed with 10kΩ End of line resistor (EOL)	Normally open with 10kΩ End of line resistor (EOL)
--------------------	----------------------	--	--

### Cookie consent

We use cookies to measure the effectiveness of our documentation and whether users find what they're searching for. With your consent, you're helping us to make our documentation better.

Google Analytics

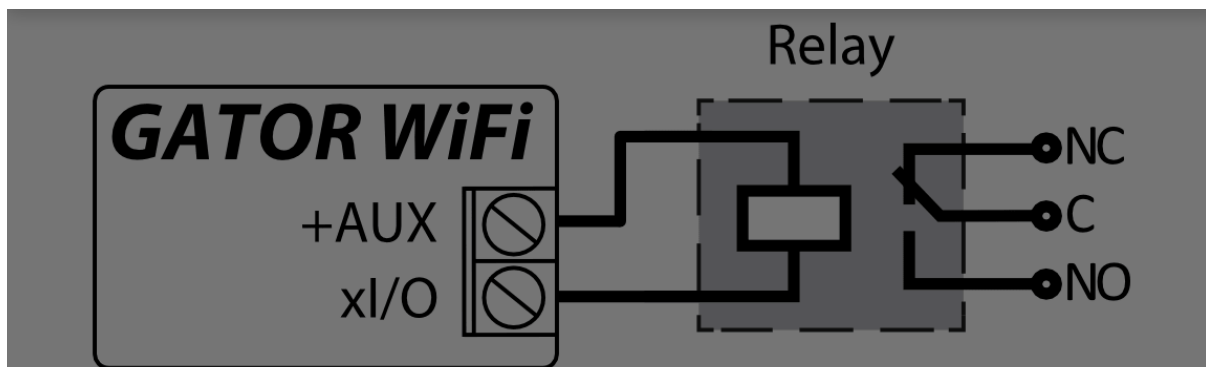

## 2.7 Schematic for connecting the LED

The "Output" mode must be set to the xI/O terminal.

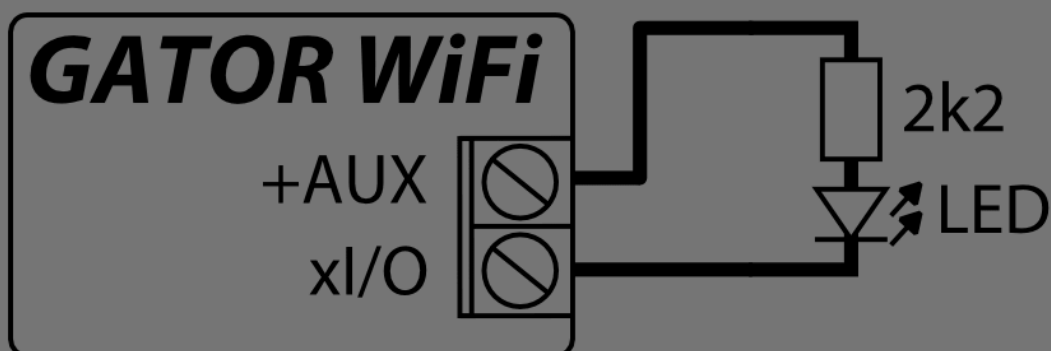

## 3. Control with the *Protegeus2* app

With Protegeus2 app users will be able to control controller remotely. They will also be able to see the system state and receive all system event messages.

1. Download and launch the Protegeus2 app or use the browser version of Protegeus2 at [www.protegeus.app](http://www.protegeus.app).



### Cookie consent

We use cookies to measure the effectiveness of our documentation and whether users find what they're searching for. With your consent, you're helping us to make our documentation better.

- Google Analytics



### ⚠ IMPORTANT

When adding the controller to Protegus2 app:

1. The power supply must be turned on („**STATUS**“ LED must blink green);
2. Must be registered in to network („**NETWORK**“ LED must be green solid and blink yellow).

Choose “Add new system”.

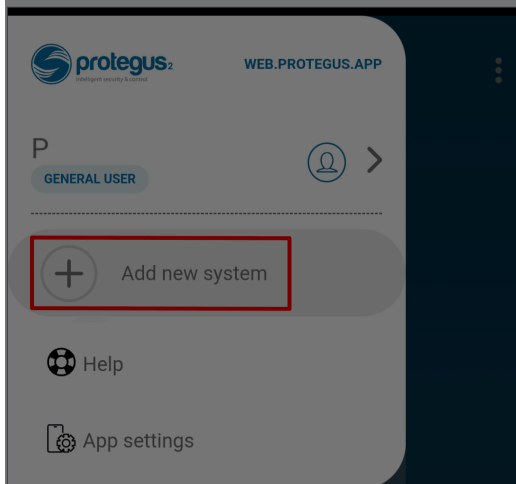

Enter the controller “Unique ID (IMEI)” number found on the product or on the packaging sticker. Press “Next”.

### Cookie consent

We use cookies to measure the effectiveness of our documentation and whether users find what they're searching for. With your consent, you're helping us to make our documentation better.

Google Analytics

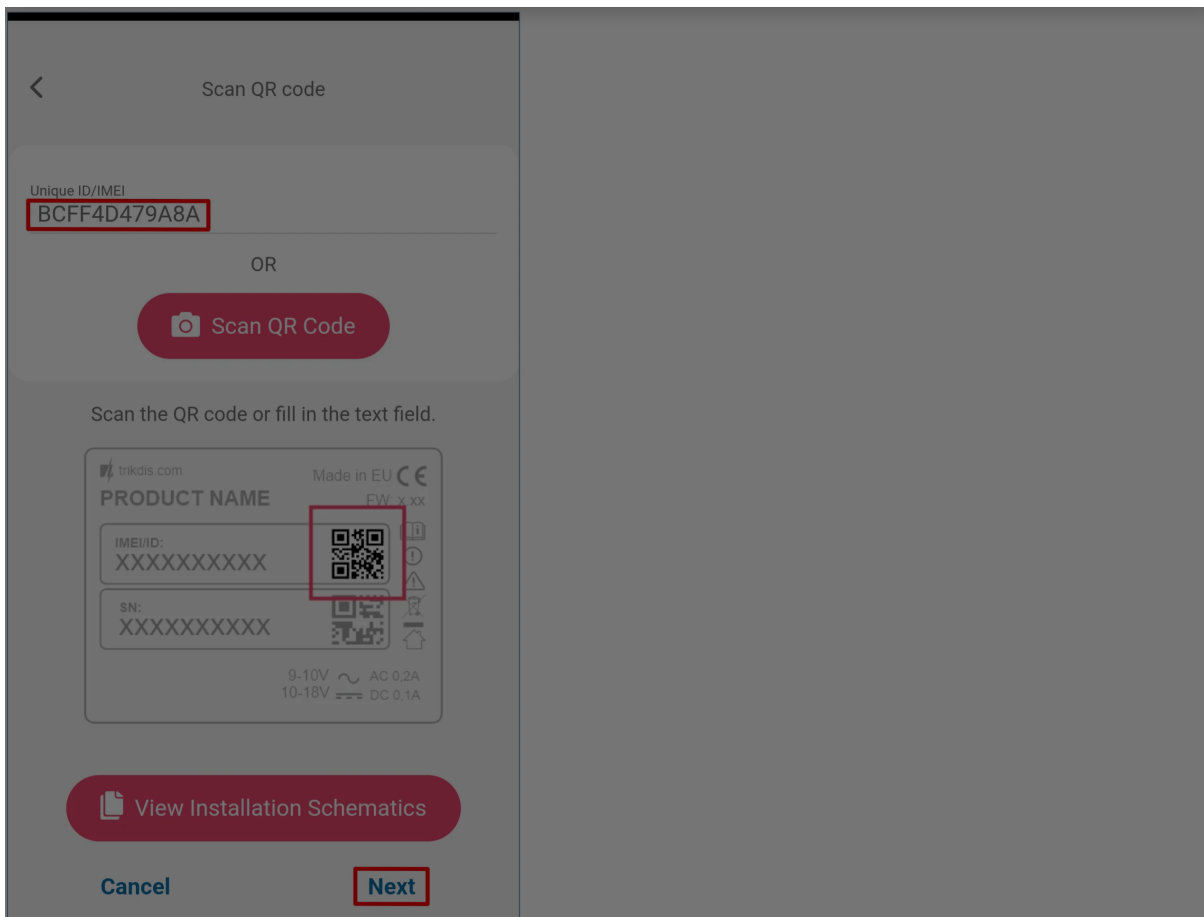

Press **"Start WiFi configuration WP17"**.

### Cookie consent

We use cookies to measure the effectiveness of our documentation and whether users find what they're searching for. With your consent, you're helping us to make our documentation better.

Google Analytics

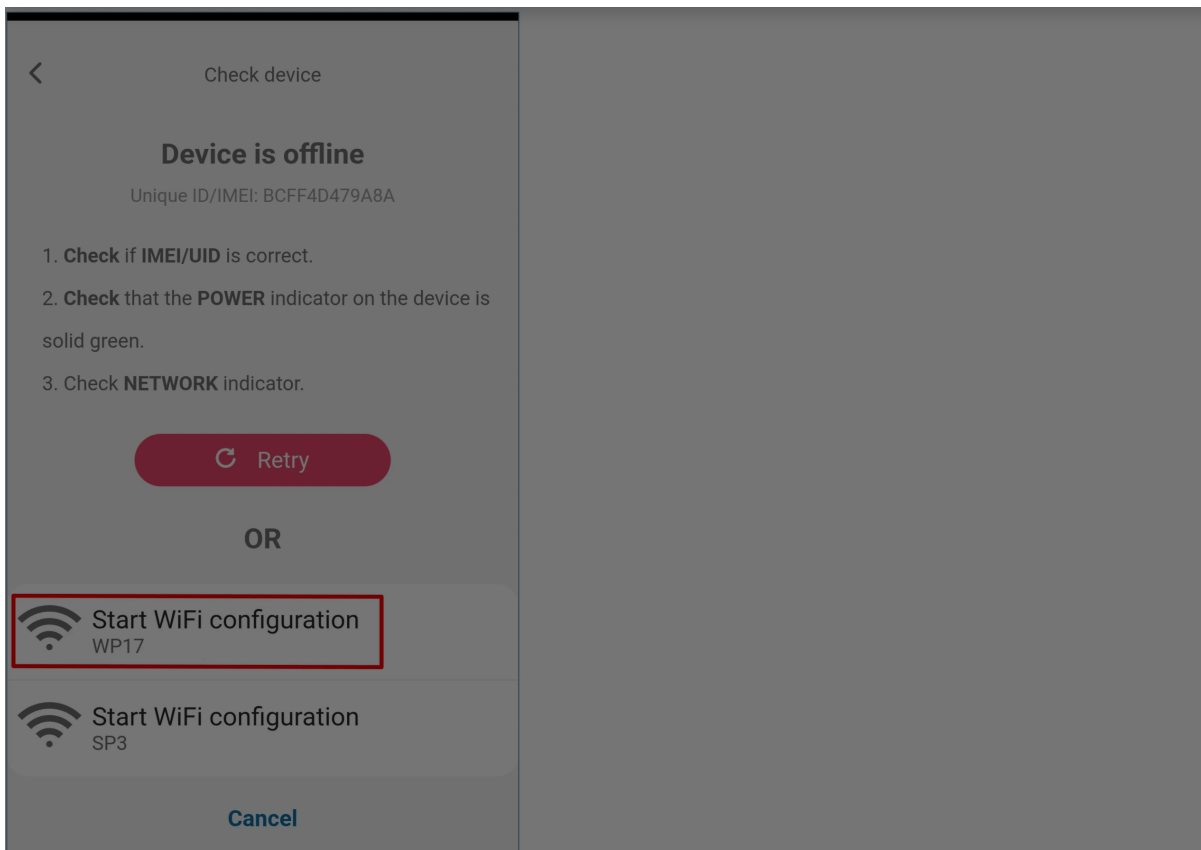

Use a flathead screwdriver to remove the cover of the GATOR WiFi. Press and hold the **"PAIR"** button for 3 seconds. The **"NETWORK"** indicator will start to flash green and yellow rapidly. Release the button. The GATOR WiFi controller has entered registration mode with the Wi-Fi network.



## Cookie consent

We use cookies to measure the effectiveness of our documentation and whether users find what they're searching for. With your consent, you're helping us to make our documentation better.

Google Analytics



Wait until the GATOR WiFi (WP17) controller is found. Click "OK".

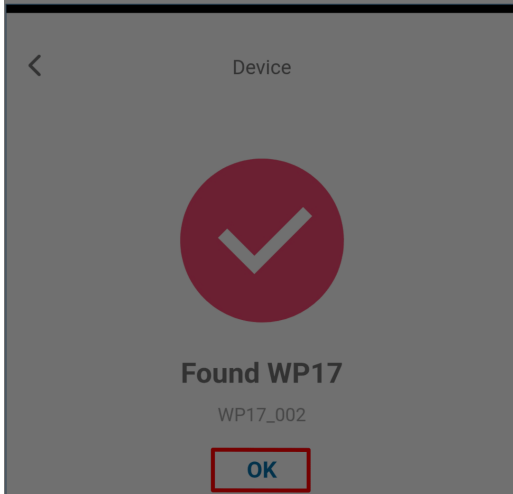

Select the WiFi network to which the GATOR WiFi controller will be connected.

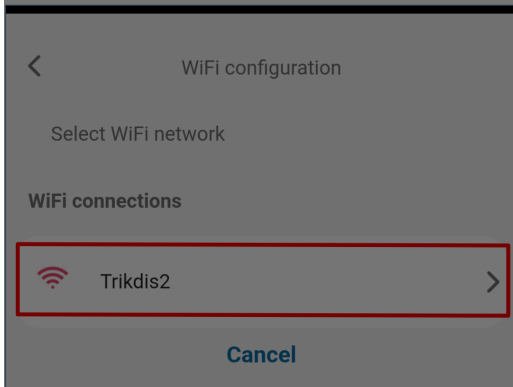

Enter the WiFi network password. Click "OK".

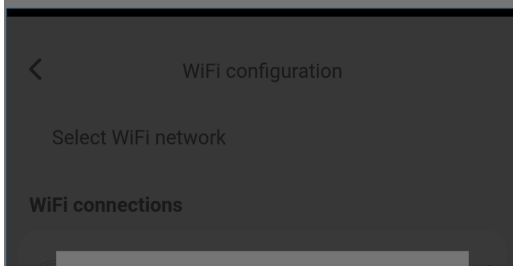

## Cookie consent

We use cookies to measure the effectiveness of our documentation and whether users find what they're searching for. With your consent, you're helping us to make our documentation better.

Google Analytics

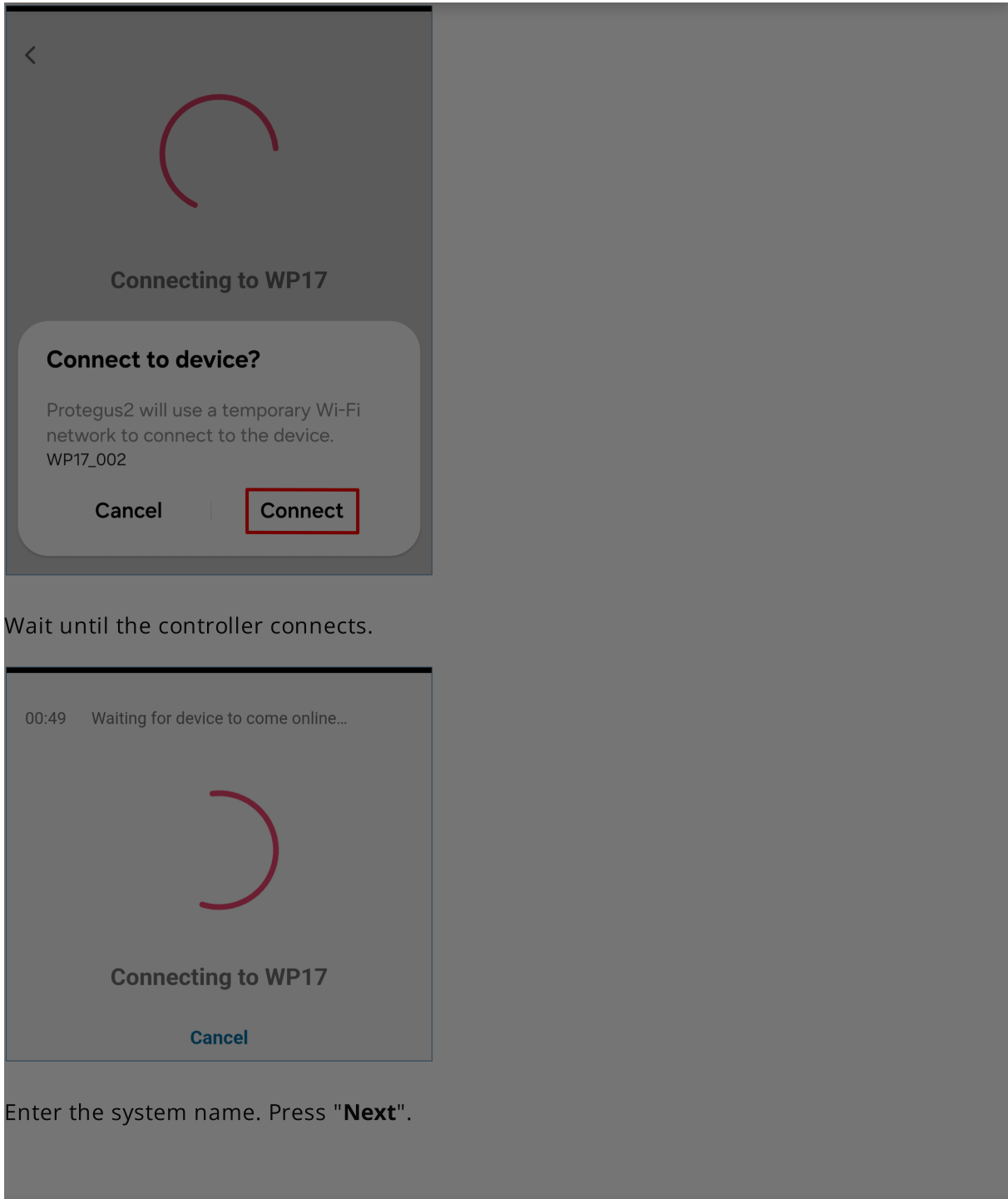

Enter the system name. Press "**Next**".

**Cookie consent**

We use cookies to measure the effectiveness of our documentation and whether users find what they're searching for. With your consent, you're helping us to make our documentation better.

Google Analytics



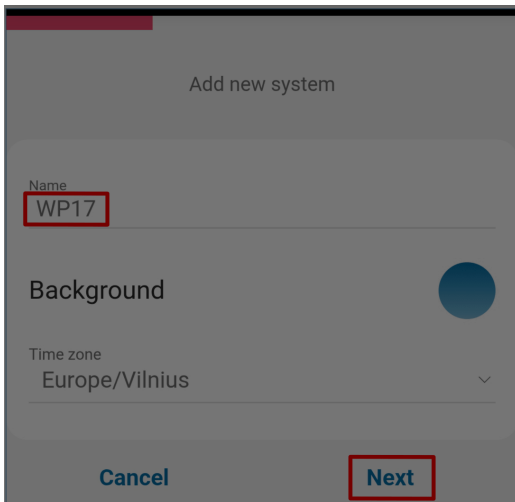

Add new system

Name  
WP17

Background

Time zone  
Europe/Vilnius

Cancel Next

Press „Skip“.

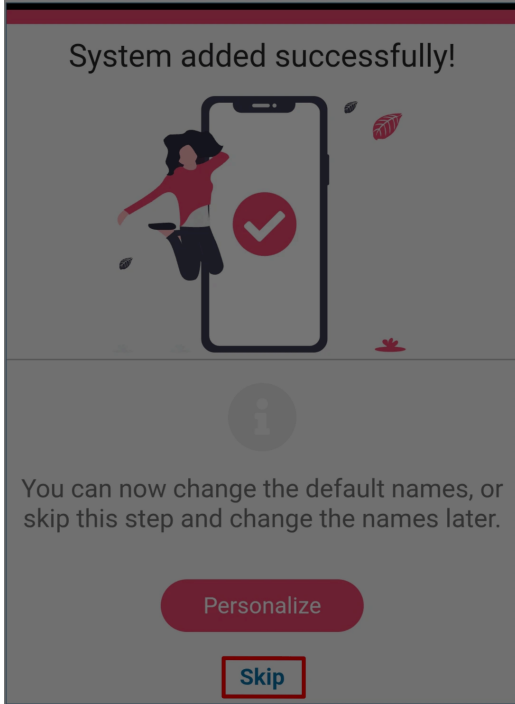

System added successfully!

You can now change the default names, or skip this step and change the names later.

Personalize Skip

Wait 1 minute. The GATOR WiFi controller will exit the pairing mode on its own after a few minutes (or press and hold the **PAIR** button for 3 seconds until the **NETWORK** indicator

### Cookie consent

We use cookies to measure the effectiveness of our documentation and whether users find what they're searching for. With your consent, you're helping us to make our documentation better.

Google Analytics

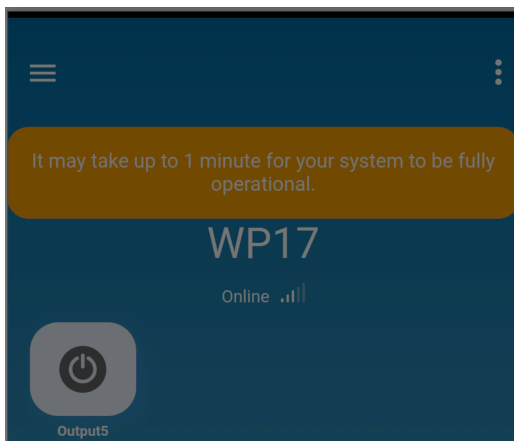

Activate the PGM output by clicking on the "**Output5**" icon.

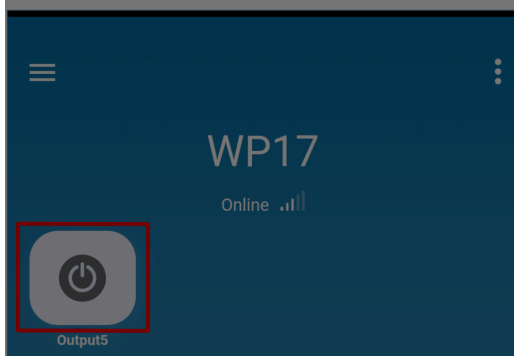

## 4. Adding a Widget on your phone

The gate control Widget can be placed on your phone's home screen. The controller must be registered to Protegus2 cloud. Log in to Protegus2 app on your phone. Close the Protegus2 window.

Touch the screen with your finger and hold. A settings bar will appear.

1. Press "**Widgets**".

### Cookie consent

We use cookies to measure the effectiveness of our documentation and whether users find what they're searching for. With your consent, you're helping us to make our documentation better.

- Google Analytics



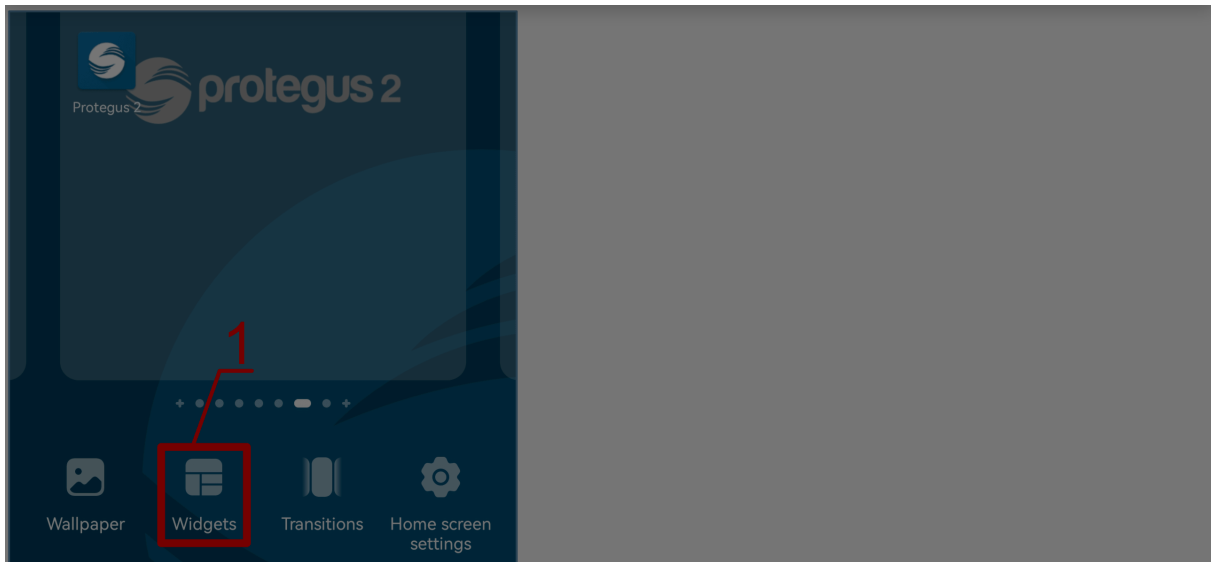

Find Protegus2 in the settings bar.

2. Select „Protegus2“.

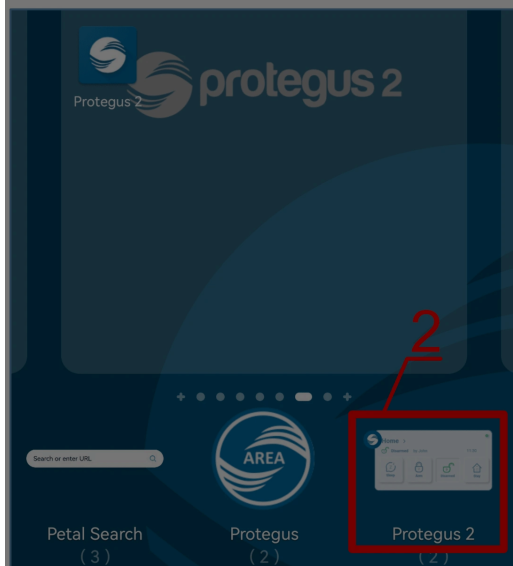

3. Click on „Switch Protegus2“.

## Cookie consent

We use cookies to measure the effectiveness of our documentation and whether users find what they're searching for. With your consent, you're helping us to make our documentation better.

Google Analytics



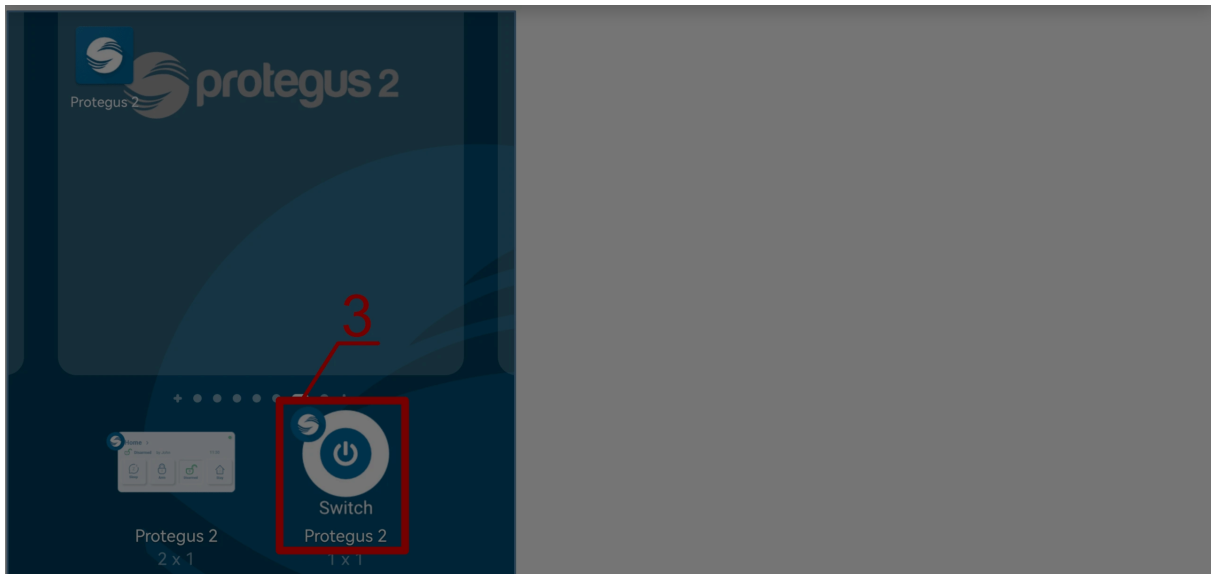

4. Select “WP17 Output5” controller output.

5. Click on “ADD WIDGET”.

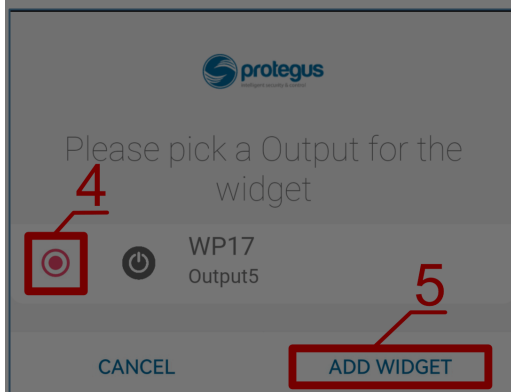

3. An icon will appear on the phone’s screen.

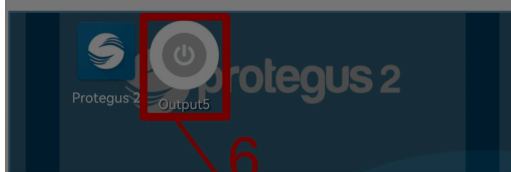

### Cookie consent

We use cookies to measure the effectiveness of our documentation and whether users find what they're searching for. With your consent, you're helping us to make our documentation better.

Google Analytics



4. Return to the home screen. Press the icon.

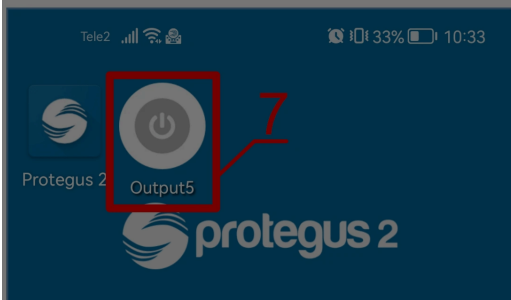

A circle that shows when the PGM is turned on will appear on the screen.



5. When the controller is connected to the automatic gate with gate state indication, the icon will show the state of the open/closed gates.

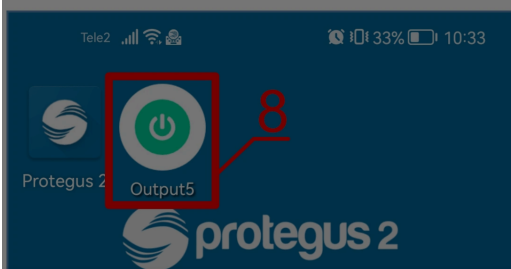

### Cookie consent

We use cookies to measure the effectiveness of our documentation and whether users find what they're searching for. With your consent, you're helping us to make our documentation better.

Google Analytics



2. Using a flat-head screwdriver, remove the GATOR WiFi's lid as shown below:

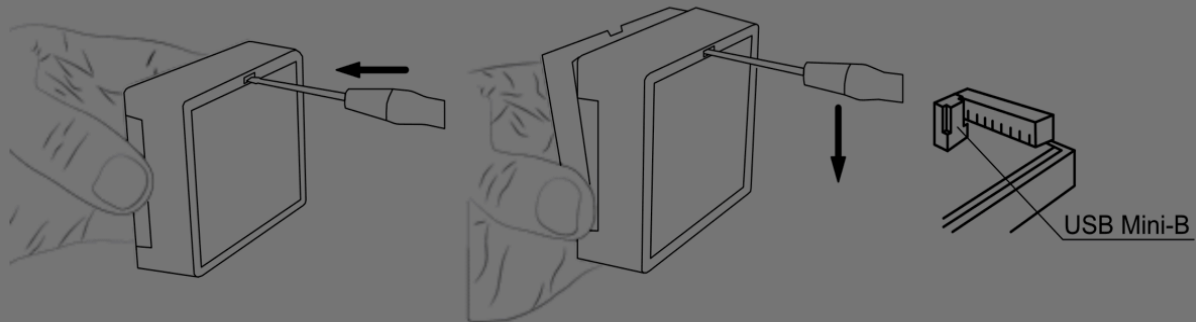

1. Connect the GATOR WiFi to a computer using a USB Mini-B cable.
2. Launch the configuration software TrikdisConfig. The program will automatically recognize the connected device and will automatically open the GATOR WiFi configuration window.
3. Click **Read [F4]** to see current GATOR WiFi parameters. If prompted, enter administrator's code in the pop-up window.

#### NOTE

The button **Read [F4]** will make the program read and show the settings currently saved on the device. / The button **Write [F5]** will save the settings made in the program to the device. / The button **Save [F9]** will save the settings into a configuration file. You can upload the saved settings to other devices later. This allows to quickly configure multiple devices with the same settings. / The button **Open [F8]** will allow to choose a configuration file and open saved settings. / If you want to revert to default settings, click on the "**Restore**" button at the bottom left of the window.

## 5.1 TrikdisConfig status bar

After connecting the GATOR WiFi to the TrikdisConfig software, the software will show

### Cookie consent

We use cookies to measure the effectiveness of our documentation and whether users find what they're searching for. With your consent, you're helping us to make our documentation better.

Google Analytics



Name	Description
IMEI/Unique ID	The device's MAC number
State	Operational state
Device	Device type (must show WP17_xxxx)
SN	Device's serial number
BL	Launcher version
FW	Device's firmware version
HW	Device's hardware version
State	Type of connection with the software (with USB or remote)

When the button **Read [F4]** is clicked, the program will read and show the settings currently saved on the GATOR WiFi. With TrikdisConfig, adjust the required settings according to the program window descriptions below.

## 5.2 „System options“ windows

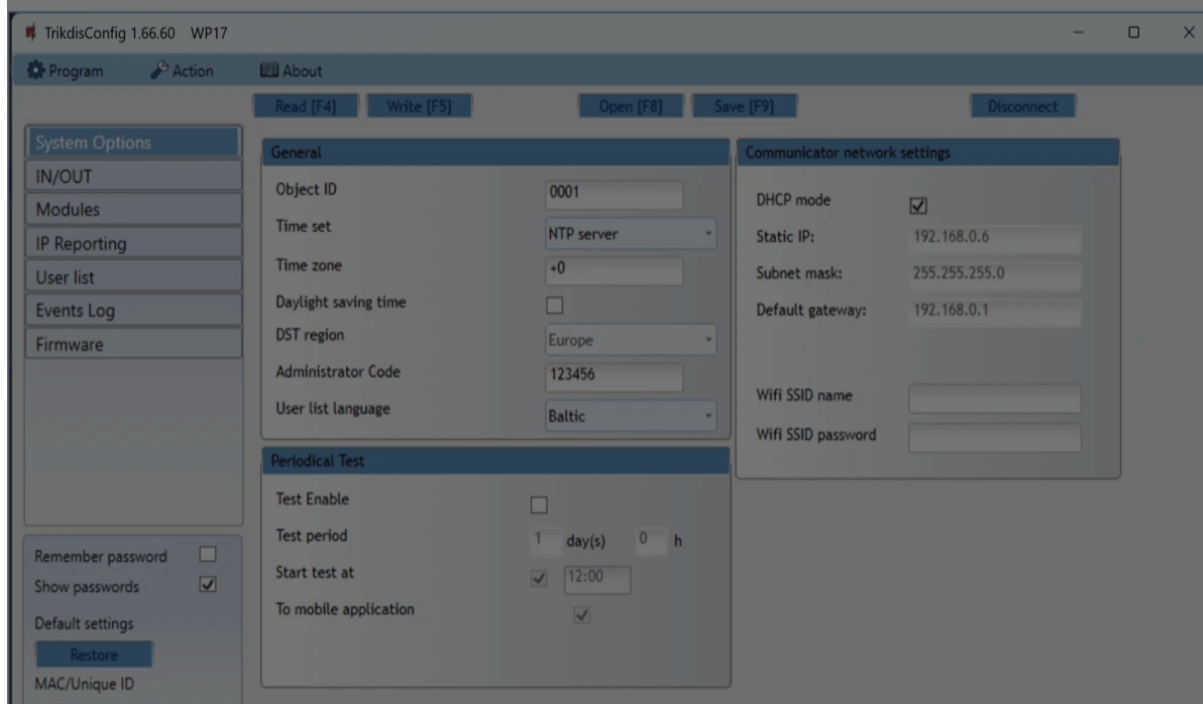

### Cookie consent

We use cookies to measure the effectiveness of our documentation and whether users find what they're searching for. With your consent, you're helping us to make our documentation better.

Google Analytics



- **Daylight saving time** – checking the box will enable automatic time change in the spring/autumn months..
- **DST region** – select the region to which your country belongs.
- **Administrator Code** – with this code it is possible to change all of the parameters of the controller.
- **User list language** – select a language (The user list can be entered in the characters of the selected language).

#### Settings group „Periodic test“

- **Test Enable** – if the box is ticked, periodic test messages are enabled.
- **Test period** – setting of test sending time period.
- **Start test at** – setting of test start time.
- **To mobile application** – if the box is ticked, the test message will be sent to Protegus2.

#### Settings group „Communicator network settings“

- **DHCP mode** – WiFi controller’s mode for registering to network (manual or automatic).
- **Static IP** – static IP address for when manual registering mode is set.
- **Subnet mask** – subnet mask for when manual registering mode is set.
- **Default gateway** – gateway address for when manual registering mode is set.
- **Wifi SSID name** – enter the Wi-Fi network name, to which the controller GATOR WiFi will connect.
- **Wifi SSID password** - enter the Wi-Fi network password.

## 5.3 „IN/OUT“ windows

### „IN/OUT“ tab

#### Cookie consent

We use cookies to measure the effectiveness of our documentation and whether users find what they're searching for. With your consent, you're helping us to make our documentation better.

- Google Analytics

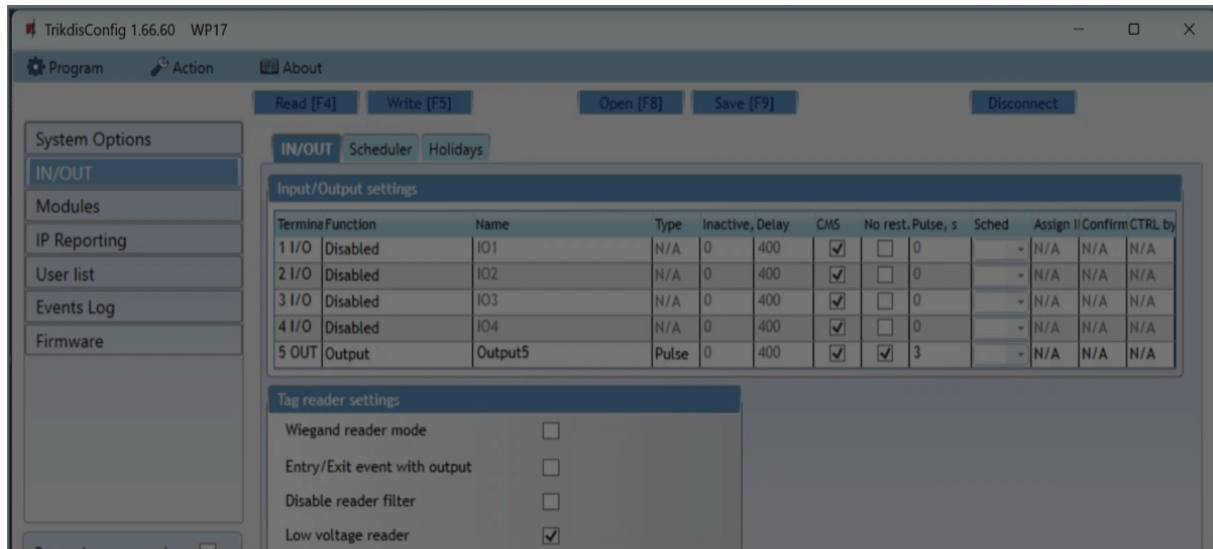

Input / Output settings window.

### Settings group „Input/Output settings“

- **Terminal** – controller’s input and output terminal numbers.
- **Function** – terminal type (input, output, disabled).
- **Name** - enter the name of the IN input or OUT output.
- **Type** – specify input type (NC, NO, EOL=10kΩ).
- **Inactive** –input will be inactive for specified time after first activation. Enter 0 if you want to turn this function off.
- **Delay** - input (zone) reaction time, ms.
- **CMS** – if box is ticked, the message will be sent to CMS (Central Monitoring Station) and to Protegus2.
- **No rest.** – do not send restore event.
- **Pulse** – time for which the output is turned on, when output is set as “Pulse” type.
- **Sched** – assign a schedule number for controlling the output.
- **Assign IN** – assign input (IN) to output to see the actual state of the device depending

### Cookie consent

We use cookies to measure the effectiveness of our documentation and whether users find what they're searching for. With your consent, you're helping us to make our documentation better.

- Google Analytics



- **Disable reader filter** - tick the box if want disable internal device filter for reader that send short pulses.
- **Low voltage reader** - tick the box if you are using low voltage readers.

## „Scheduler“ tab

Outputs can be controlled automatically according to a set schedule.

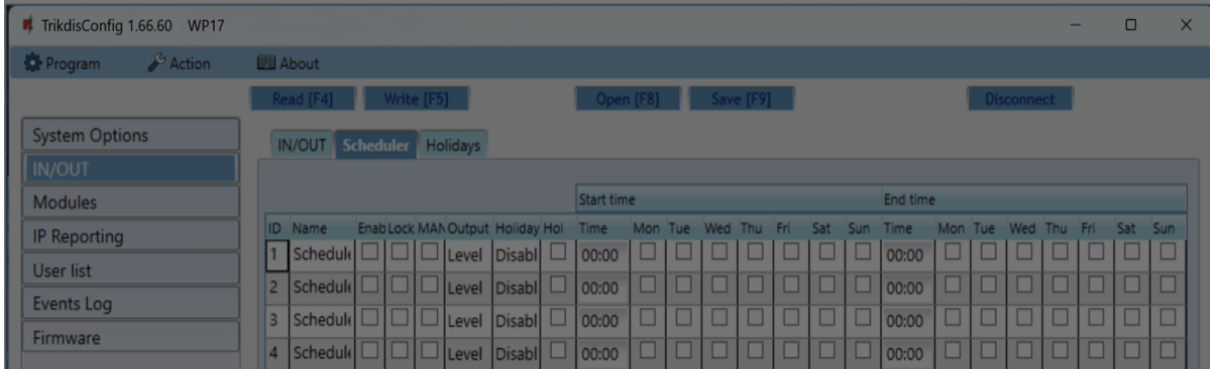

The OUT output can be activated according to a set schedule. It is necessary to specify the time and days of the week, enable the schedule, and assign the schedule to the Output.

- **Name** - enter the name of the schedule.
- **Enable** - enable the time schedule for when the controller will control the output.
- **Lock** - check the box to prevent the output from being controlled by other means when it is triggered according to the specified schedule.
- **MANUAL** - check the box to prevent the scheduler from enabling the output at startup. The schedule will only start running when the output is activated by the user.
- **Output mode** - specify the mode of operation of the PGM output: **“Level”** - the output will be activated for the specified time period; **“Pulse”** - the output will be activated at the start and end of the schedule for the set pulse duration.
- **Holiday mode** - specify the mode of how the time schedule should work when the holidays begin.
- **Hol** - tick the box to use holiday time when the schedule triggers on holidays.

## Cookie consent

We use cookies to measure the effectiveness of our documentation and whether users find what they're searching for. With your consent, you're helping us to make our documentation better.

- Google Analytics



Enter the calendar holidays during which it will be possible to set the additional activation of the PGM output provided in the Scheduler table.

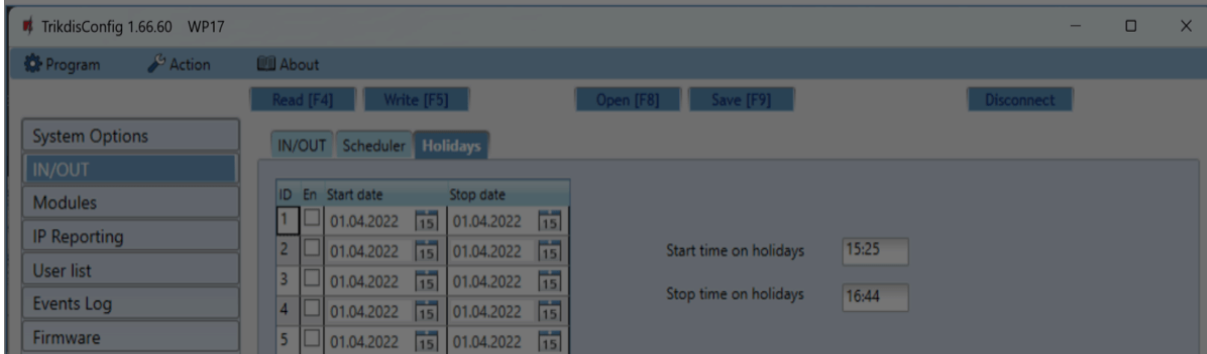

- **En.** – check the box to specify a specific holiday interval.
- **Start date** – specify the start date of the holidays.
- **Stop date** – specify the end date of the holidays.
- **Start time on holidays** – specify the start time of the holidays.
- **Stop time on holidays** - specify the end time of the holidays.

## 5.4 “Modules” window

### „Modules” tab

iO-LORA modules can be connected to the GATOR WiFi controller.

By connecting the RF-LORA transceiver, up to 8 iO-LORA wireless expansion modules can be connected to the GATOR WiFi controller. RFID readers connected to the iO-LORA wireless expansion modules can control up to 8 additional doors (GATOR WiFi gate controller operating program version 1.21 or later). One iO-LORA expansion module with one RFID reader controls only one door.

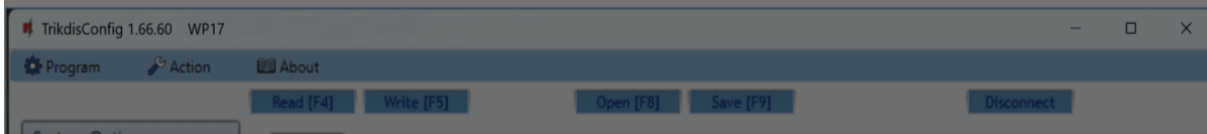

### Cookie consent

We use cookies to measure the effectiveness of our documentation and whether users find what they're searching for. With your consent, you're helping us to make our documentation better.

- Google Analytics



- **Modules** – select from the list the module connected to the gate controller.
- **Serial No.** – enter the module serial number (6 digits), which is indicated on stickers on the module's case and packaging.

## 5.5 „IP reporting“ windows

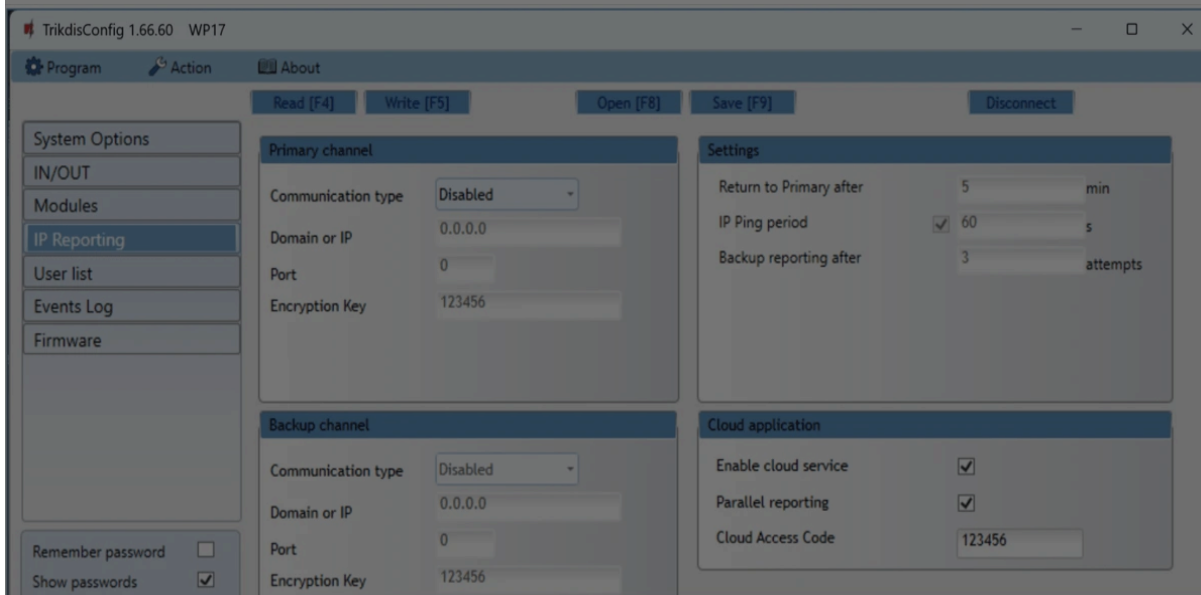

### Settings group „Primary channel“

Messages from the GATOR WiFi controller can be sent to the CMS. This requires setting up communication channels with the CMS receiver.

- **Communication type** – choose the type of communication (TCP/IP, UDP/IP) with the CMS (Central Monitoring Station) receiver.
- **Domain or IP** – enter the receiver's domain or IP address.
- **Port** – enter the receiver's network port number.
- **Encryption Key** – 6-digit message encryption key that must match the encryption key of the CMS receiver.

### Cookie consent

We use cookies to measure the effectiveness of our documentation and whether users find what they're searching for. With your consent, you're helping us to make our documentation better.

- Google Analytics



- **Backup reporting after** – specify amount of attempts to connect with the main channel, after which the controller will automatically connect to the backup connection channel.

### Settings group „Cloud application“

- **Enable cloud service** – enable Protegus2service, the GATOR WiFi will be able to exchange data with the Protegus2app and also remote configuration with TrikdirConfig will be possible.
- **Parallel reporting** – the messages are sent simultaneously to the CMS, Protegus. When not enabled, messages to Protegus2 will be sent only after being sent to CMS.
- **Cloud Access Code** – 6-digit code for connecting with Protegus2 (default code - 123456).

## 5.6 „User list“ window

### „User list“ tab

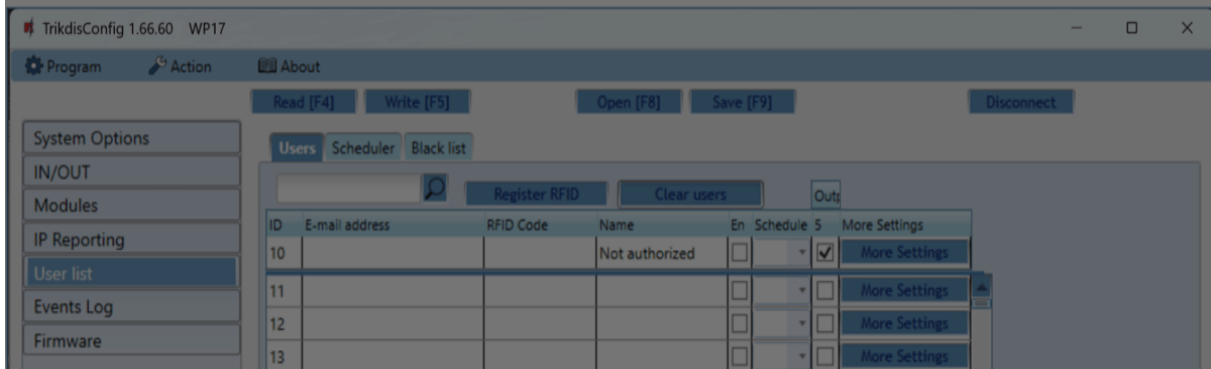

- **E-mail address** – specify user's e-mail address.
- **RFID code** - enter the user's RFID card (pendant) ID number if an RFID reader is connected to the controller and the user has an RFID card (pendant).
- **Name** - specify user's name.
- **En** – if boxed is ticked, user is allowed to control outputs OUT.
- **Sched.** – assign a schedule (specify a schedule number) for when the user can control

### Cookie consent

We use cookies to measure the effectiveness of our documentation and whether users find what they're searching for. With your consent, you're helping us to make our documentation better.

- Google Analytics



**User settings (numbers from 11 to 1010)** - Enabled – boxed is ticked, user is allowed to control outputs OUT.

- Name – specify user's name.
- E-mail address – specify user's e-mail address.
- RFID code – when an RFID reader with keypad (Wiegand 26/34) is connected to the controller, the ID number of the RFID card (pendant) can be assigned to the user.
- Keypad code – when RFID reader with keypad (Wiegand 26/34) is connected to the controller, the user can be assigned a user code.
- Assign scheduler – assign a schedule (specify a schedule number) for when the user can control outputs OUT.
- Valid from – specify date and time from when the user can control the controller.

The screenshot shows a 'User settings' window with the following fields and values:

- ID: 11
- Enabled:
- Name:
- E-mail address:
- RFID code:
- Keypad code:
- Assign schedule:
- Valid from:  24.01.2025 00:00
- Valid until:  25.01.2025 00:00
- Enable counter:
- Set counter:
- Current counter:
- Can control outputs:  OUT5

A 'Save' button is located at the bottom of the form.

- **Valid until** – specify date and time until when the user can control the controller.
- **Enable counter** – check the box to enable the counter.

## Cookie consent

We use cookies to measure the effectiveness of our documentation and whether users find what they're searching for. With your consent, you're helping us to make our documentation better.

- Google Analytics



### 5.6.1 RFID pendant (card) registration

Connect the RFID reader to the controller (see p.2.3 " Schematic for connecting for RFID reader (Wiegand 26/34)"). Turn on the power to the controller. Connect the USB Mini-B cable to the controller. In the „IN / OUT” window of the TrikdisConfig program, select the **“Wiegand reader mode”** field.

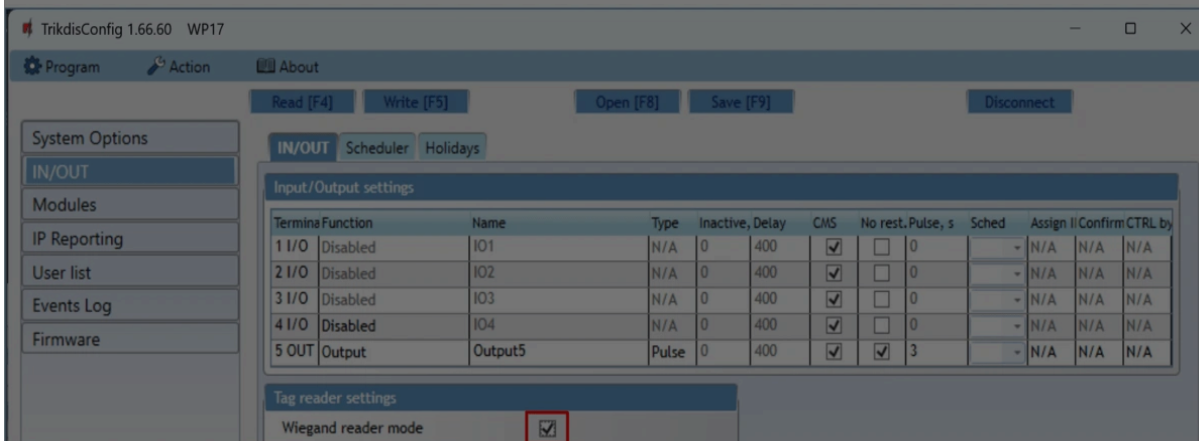

Click **“Register RFID”** in the **“User list”** window.

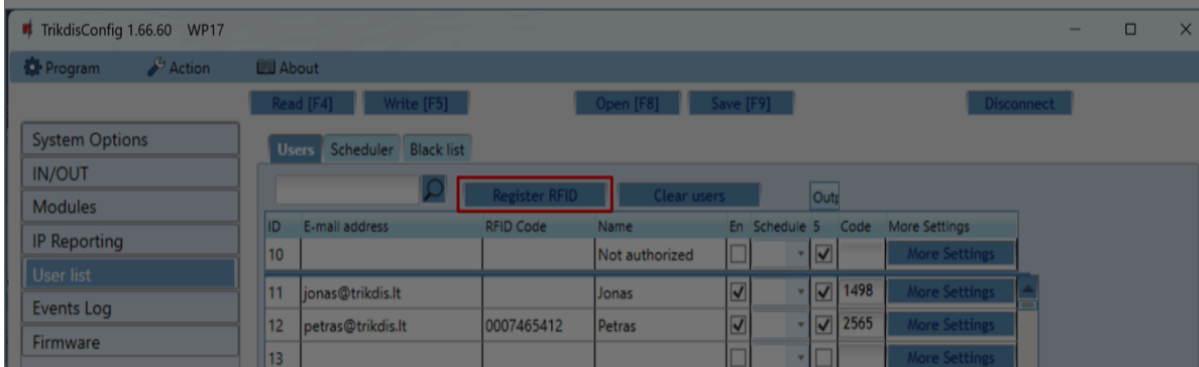

The RFID pendants (cards) registration window will open.

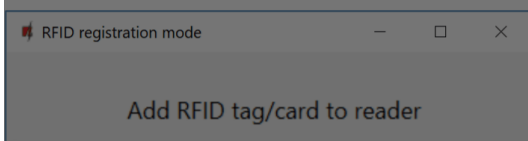

### Cookie consent

We use cookies to measure the effectiveness of our documentation and whether users find what they're searching for. With your consent, you're helping us to make our documentation better.

Google Analytics



Attach the RFID pendant (card) to the RFID reader. A new window will open when the reader scans the pendant (card). In it, “**Enter user name**” and select the “**User can control PGM Output 5**”. Press the “**ADD**” button. / Repeat the steps above to add more RFID pendant (cards).

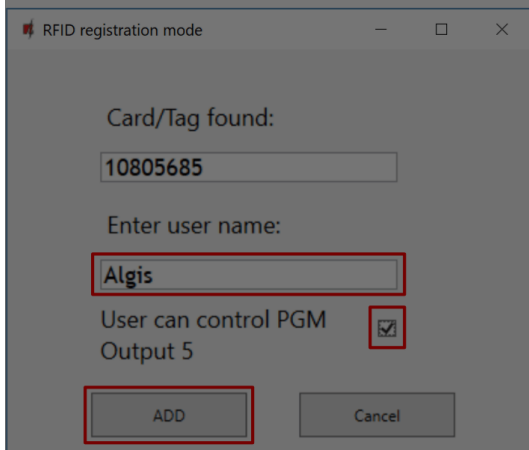

When the registration of all RFID pendant (cards) is completed, press the “**STOP registration**” button. / Press the button **Write [F5]** to save the RFID pendant list to the controller.

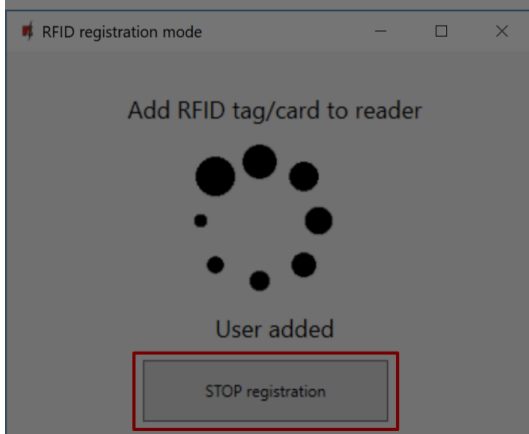

## Cookie consent

We use cookies to measure the effectiveness of our documentation and whether users find what they're searching for. With your consent, you're helping us to make our documentation better.

Google Analytics



## „Scheduler“ tab

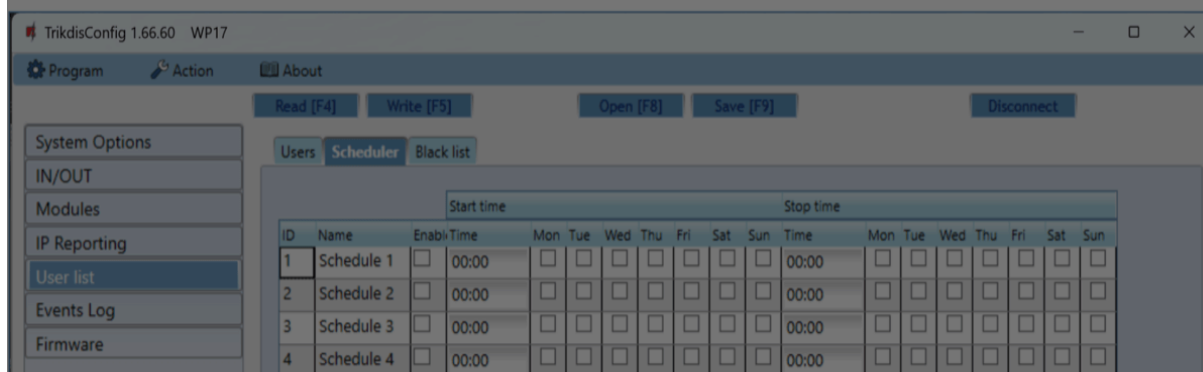

A schedule can be created for the user, specifying the time and days of the week when he will be able to control the output.

- **Name** - enter a name for the schedule.
- **Enable** – enable time schedule when the user will be able to control the controller’s outputs.
- **Start time** – specify time and days of the week from when the user can control controller’s outputs.
- **Stop time** – specify time and days of the week until when the user can control controller’s outputs.

## „Black list“ tab

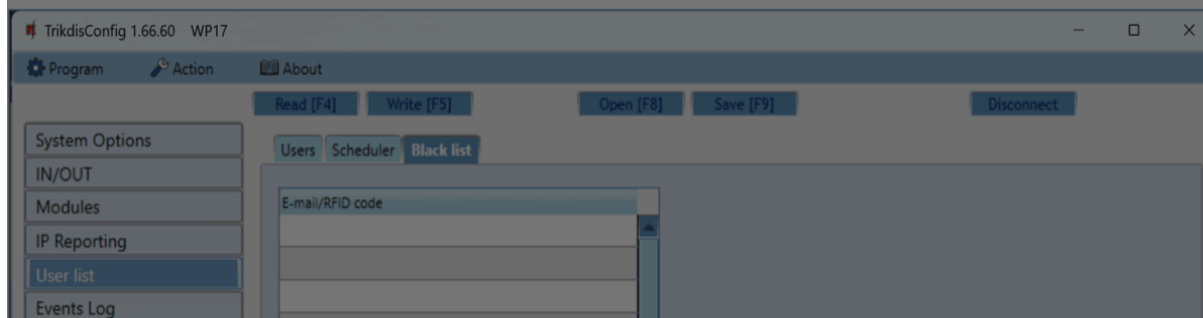

The “**Black list**” contains e-mail addresses of users, ID numbers of RFID cards who are

## Cookie consent

We use cookies to measure the effectiveness of our documentation and whether users find what they're searching for. With your consent, you're helping us to make our documentation better.

- Google Analytics



## 5.7 „Event Log“ window

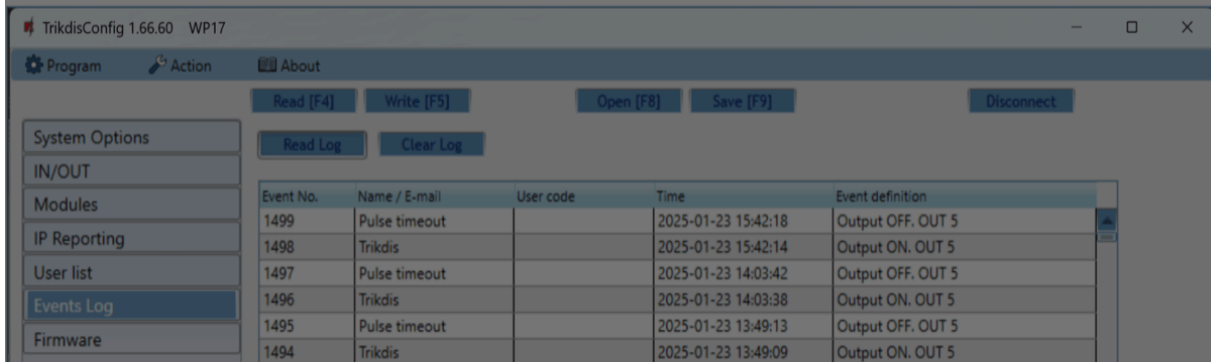

Click the button **“Read Log”**. The **“Events Log”** will be read from the controller’s memory. The **“Events log”** provides information about the controller’s actions and its internal events.

## 5.8 Restore default settings

Connect GATOR WiFi to your computer using a USB Mini-B cable. To restore the default settings of the GATOR WiFi controller you need to click the **“Restore”** button in the TrikisConfig program window.

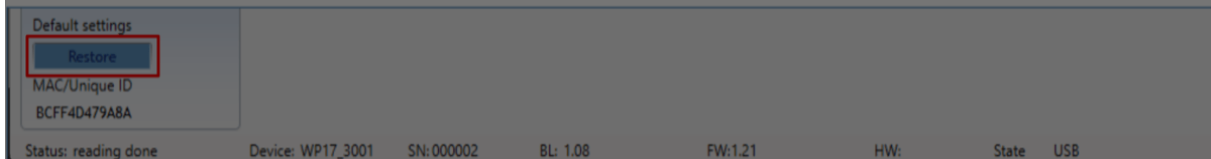

## 6. Setting parameters remotely

### ⚠ IMPORTANT

Remote configuration will only work when:

1. Protegus2 service is enabled. Enabling the service is described in chapter 5.5 "IP reporting"

### Cookie consent

We use cookies to measure the effectiveness of our documentation and whether users find what they're searching for. With your consent, you're helping us to make our documentation better.

Google Analytics



3. Launch the configuration program TrikdisConfig and in the field **“Unique ID”** of the **“Remote access”** section enter the **“MAC”** number of your controller (the MAC number is given on the stickers that can be found on the lower part of the device’s case and on the packaging).

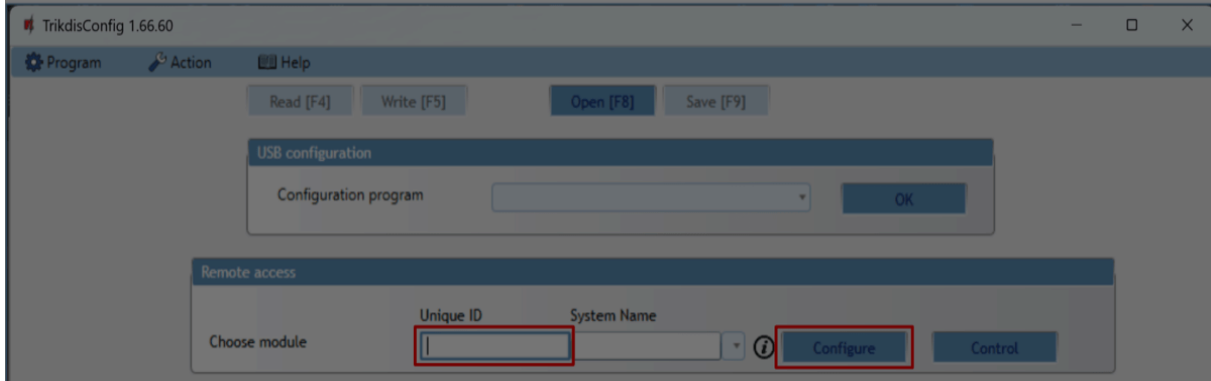

4. In the field **“System Name”** you can give any name to this controller. Click **“Configure”**.
5. The controller configuration window will open. Click the button **Read [F4]** for the program to read the parameters currently set for the controller. If a window for entering the *Administrator code* opens, enter the six-symbol *administrator code*. To make the program remember the code, tick the box next to **“Remember password”** and click the button **Write [F5]**.
6. Set the desired settings for the controller and afterwards click **Write [F5]**. To disconnect from the controller click **“Disconnect”** and exit the TrikdisConfig program.

## 7. Testing of controller GATOR WiFi

When configuration and installation are finished, test the system:

1. Check if the power is on;
2. Check network connectivity („**NETWORK**” indicator must be green solid and blink yellow);
3. To test the GATOR WiFi’s inputs, trigger them and make sure that the recipients get correct messages:

### Cookie consent

We use cookies to measure the effectiveness of our documentation and whether users find what they're searching for. With your consent, you're helping us to make our documentation better.

- Google Analytics



## 8. Updating firmware manually

### NOTE

When the GATOR WiFi is connected to TrikdConfig, the program will offer to update the device's firmware if updates are available. Updates require an internet connection. / If antivirus software is installed in your computer, it might block the automatic firmware update function. In this case you will have to reconfigure your antivirus software.

The GATOR WiFi's firmware can also be updated and changed manually. All prior GATOR WiFi parameters remain after update. When writing manually, the firmware can be changed to an older or a newer version. Follow these steps:

1. Launch ***TrikdConfig***.
2. Connect the GATOR WiFi to a computer using a USB Mini-B cable or connect to the GATOR WiFi remotely. If a newer version of firmware is available, the program will offer to install it.
3. Choose the menu branch "**Firmware**".
4. Click the "**Open firmware**" button and choose the required firmware file.

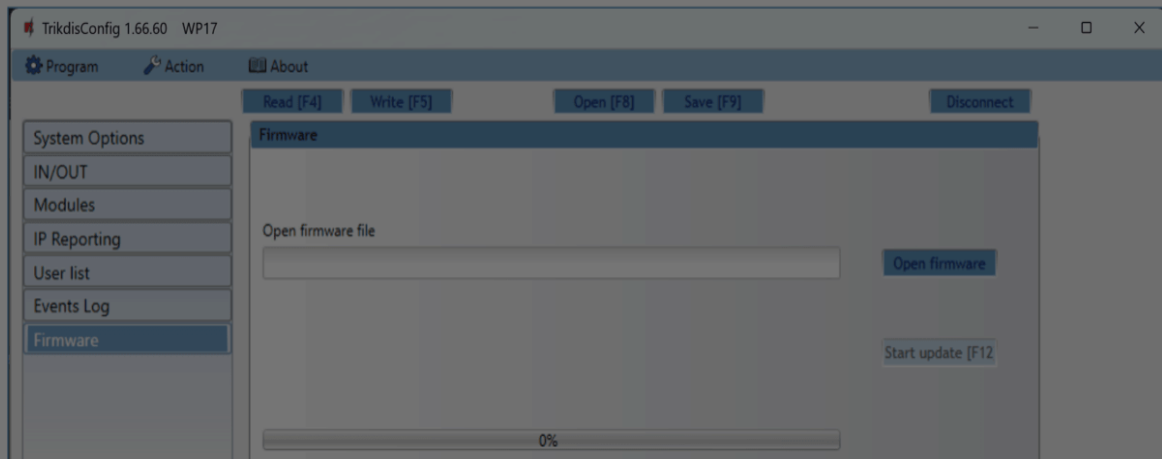

### Cookie consent

We use cookies to measure the effectiveness of our documentation and whether users find what they're searching for. With your consent, you're helping us to make our documentation better.

- Google Analytics



Always disconnect the power supply before making any electrical connections.

Any changes, modifications or repairs not authorized by the manufacturer shall render the warranty void.



Please adhere to your local waste sorting regulations and do not dispose of this equipment or its components with other household waste.

### Cookie consent

We use cookies to measure the effectiveness of our documentation and whether users find what they're searching for. With your consent, you're helping us to make our documentation better.

Google Analytics